



# TECHNICAL BULLETIN HID BALLAST KIT

## HIGH PRESSURE SODIUM BK S50/250W/Q

<b>ANSI Code:</b> S50	<b>Product Code:</b> 91577	
<b>Features:</b>	• Class H Insulation	• Cool / Quite Operation
	• Vacuum Impregnated Core & Coil	• Will Fit Existing CWA Ballast Fixtures
	• Excellent Thermal Performance	• Permanently Marked Leads

### BALLAST SPECIFICATIONS

Input Voltage	120	208	240	277	V
Circuit Type	CWA				
Power Factor	0.97				
<b>Regulation</b>					
Line Volts	± 10%				
Lamp Watts	Within Trapezoid				
<b>Line Current</b>					
Operating Current	2.5	1.43	1.24	1.09	A
Open Circuit Current	1.23	0.7	0.63	0.55	A
Starting Current	1.82	1.06	0.92	0.78	A
Recommended Fuse	6	4	3	3	A
<b>UL Temperature Ratings</b>					
Insulation Class	H (180°C)				
Coil Temperature Code	A	A	A	A	
Bench top Coil Rise, Primary	51	55	55	59	°C
Bench top Coil Rise, Secondary	51	55	67	67	°C
Input Power	295	295	295	295	W
Nominal Open Circuit Voltage	183				
Current Crest Factor	1.6				
Input Voltage at Lamp Dropout	90	156	180	208	V
Min Ambient Starting Temp	-40°F -40°C				
<b>High Potential Test</b>					
1 minute	1650				V
1 second	2000				V
<b>Open Circuit Voltage Test</b>					
Open Circuit Voltage	165 - 205				V
Input Current min	0.9	0.5	0.45	0.4	A
Input Current max	1.55	0.9	0.8	0.7	A
<b>Short Circuit Current Test</b>					
Secondary Current	3.6 - 4.5				A
Input Current min	1.1	0.65	0.55	0.45	A
Input Current max	1.95	1.15	1.0	0.85	A
<b>Core &amp; Coil Dimensions</b>					
A	1.8				Inch
B	3.73				Inch
Weight	10.5				lbs
Lead Length	12				Inch

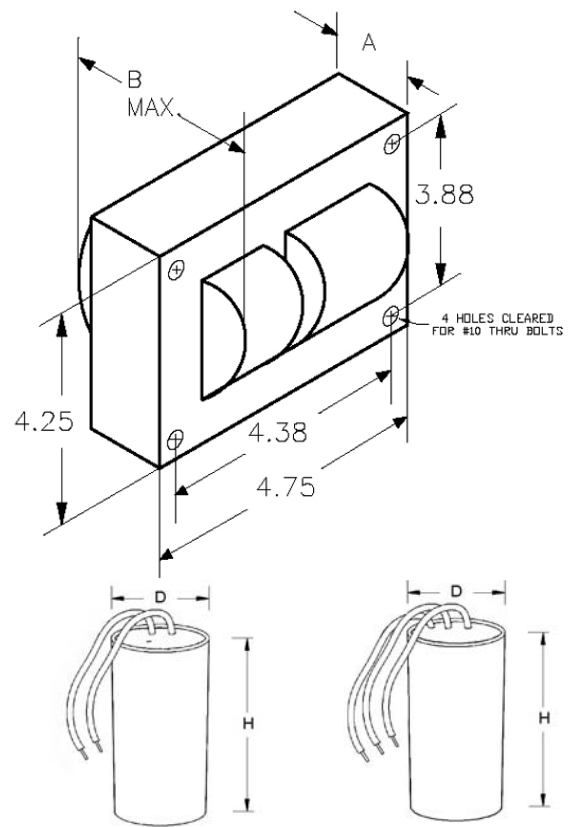
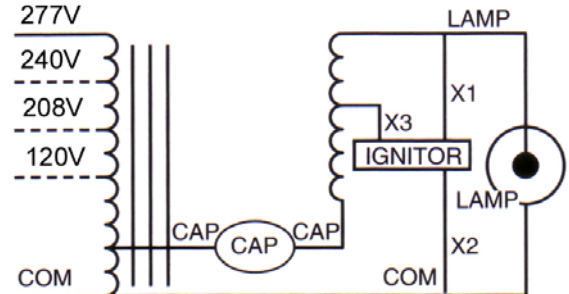

CAPACITOR

IGNITOR

### CAPACITOR SPECIFICATIONS

Dry Film non PCB		
Product Code	93368	
Capacitance	35	µF
Voltage	240	V
Diameter D	1.63	Inch
Height H	3.63	Inch
Temperature Rating	100	°C

### IGNITOR SPECIFICATIONS

Product Code	93051	
Product Description	EY2000ST	
Distance Ballast to Lamp max	20	ft
Diameter D	1.38	Inch
Height H	2.5	Inch
Temperature Rating	105	°C

ISO 9001:2008 Certified    ISO 14001:2004 Certified

OSHAS 18001:2007 Certified    ISO 17025:2005 Accredited



**EYE LIGHTING INTERNATIONAL  
OF NORTH AMERICA, INC.**  
A SUBSIDIARY OF IWASAKI ELECTRIC CO., LTD.

Address: 9150 Hendricks Rd., Mentor, OH 44060

Phone: 888-665-2677 Fax: 800-811-7395 E-Mail: [sales@eyelighting.com](mailto:sales@eyelighting.com)

Phone: (440) 350-7000 Fax: (440) 350-7001 Web: [www.eyelighting.com](http://www.eyelighting.com)



### ⚠ WARNING

#### RISK OF ELECTRICUTION

- Disconnect power to fixture before installation, when replacing components or checking connections.
- The ballast and associated components must be mounted and wired in conformance with the National Electrical Code, all applicable state and municipal codes, and UL safety standards for installation.

#### RISK OF FIRE

- Use in fixture rated for this product.

### INSTALLATION

**IMPORTANT:** Read all instructions carefully before attempting installation.

1. Remove existing ballast and associated components (capacitor, ignitor).

**NOTE:** Retain existing capacitor strap and mounting screws.

2. Mount replacement ballast on supplied brackets using the nuts and bolts supplied with kit.

**NOTE:** Ballast should be mounted with short side of bracket flush to the ballast. See figure 2.

3. Install replacement ballast and associated prewired components (capacitor, ignitor) in fixture using retained fixture screws.

**NOTE:** The capacitor should be mounted using the existing capacitor strap. Ground ballast and metal components.

4. Connect ballast to supply power using the appropriate line voltage tap as shown in the wiring diagram located on the ballast label or on the ballast wiring diagrams located on page 1.

5. Before closing fixture, ensure proper lamp wattage and type, check for proper grounding and secure component mounting.

6. Once all safety requirements have been adhered to and checked, close fixture and apply power.

### TROUBLESHOOTING

1. Insure all connections to the line; capacitor, starter, and lamp have been made properly.

2. Measure line voltage to insure correct voltage level.

3. Check for blown fuse, tripped circuit breaker, or blown bulb.

4. Verify lamp operation with known good ballast of the same type

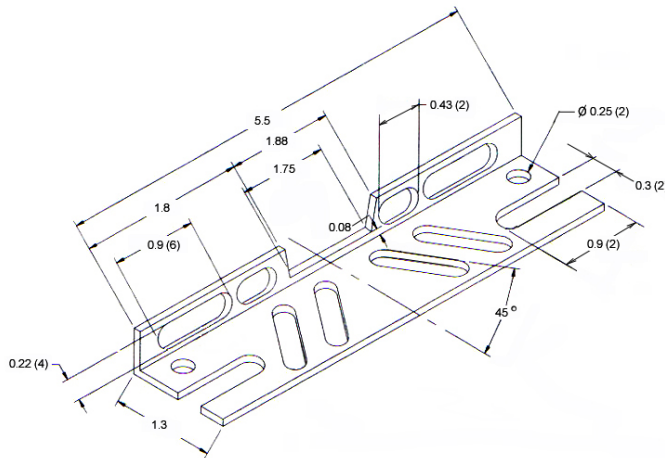

Fig.1

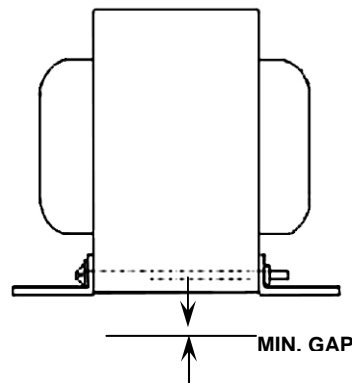

Fig.2